

TRIUMF



ANNUAL REPORT SCIENTIFIC ACTIVITIES 1999

ISSN 1492-417X

**CANADA'S NATIONAL LABORATORY
FOR PARTICLE AND NUCLEAR PHYSICS**

OPERATED AS A JOINT VENTURE

MEMBERS:

THE UNIVERSITY OF ALBERTA
SIMON FRASER UNIVERSITY
THE UNIVERSITY OF VICTORIA
THE UNIVERSITY OF BRITISH COLUMBIA

ASSOCIATE MEMBERS:

CARLETON UNIVERSITY
THE UNIVERSITY OF MANITOBA
L'UNIVERSITÉ DE MONTRÉAL
QUEEN'S UNIVERSITY
THE UNIVERSITY OF REGINA
THE UNIVERSITY OF TORONTO

UNDER A CONTRIBUTION FROM THE
NATIONAL RESEARCH COUNCIL OF CANADA

JULY 2000

The contributions on individual experiments in this report are outlines intended to demonstrate the extent of scientific activity at TRIUMF during the past year. The outlines are not publications and often contain preliminary results not intended, or not yet ready, for publication. Material from these reports should not be reproduced or quoted without permission from the authors.

ACCELERATOR TECHNOLOGY DIVISION

INTRODUCTION

Once again the ISAC project continued to be the largest user of engineering, design and fabrication effort during 1999, with an increasing fraction of the work going into supporting the ISAC experimental program. The tally of REAs (requests for engineering assistance) submitted during the year came to 49 for ISAC-related projects and 14 for other activities, surprisingly similar to last year.

The main activities for ISAC involved completion and commissioning of the hot cell and handling equipment for radioactive components, the design and fabrication of two new target modules, the MEFT beam line and various LEBT lines to experiments and the DTL tanks and radio frequency bunchers. For ISAC science the DRAGON spectrometer used the most design resources followed by the β -NMR experiment. The design of the electrostatic dipoles for DRAGON was completed and contracts for machining are about to be awarded.

For the CERN-LHC collaboration the design and fabrication of the fast wire scanners and the assembly of the 66 kV resonant power supplies used most of the effort. The ATLAS engineering group at the University of Victoria continued their work on the design of the tooling and assembly method for the HEC calorimeter modules, and developed a design for a shipping container for the modules. The final design for the signal feedthroughs was established after extensive testing.

Some progress was made on the Expt. 614 solenoid magnet shield where the design was taken to the point where steel could be ordered. There was a review of the conceptual design of the mounting and alignment of the wire chamber assembly but detailed design awaits further input.

A number of magnets were designed and fabricated this year: dipoles for DRAGON, MEFT and HEFT, quadrupoles for DRAGON, and very compact quadrupole triplets for the drift tube linac (DTL). A contract was awarded for the series production of the twin aperture quadrupoles for the LHC and its contract supervision remains a major task for magnet engineering.

The Design Office and Machine Shop were heavily loaded and outside assistance was used to cope with the demand. A significant improvement in the quality of life for the Design Office occurred when they moved out of a decaying trailer into the top floor of the ISAC office building. Thanks to good preparation and planning this move did not disrupt the design work. The Building department looked after the modifications to the new Design Office and took up residency there as

well. In addition, a number of ISAC-related building projects were carried out including some large shielded target storage modules.

The Electronics Services group provided support for the ISAC and CERN work as well as maintenance of the existing systems. Large numbers of cables were required, and technical support was given to a number of projects, such as the CERN fast blade scanner, Expt. 614 detector amplifiers and ISAC motor systems. The PC support effort was increased with a part-time position and a new effort to provide a centralized backup system for PCs was initiated. Preparations were made for Y2K.

The main effort of the Electronics Development group continued to be the support of the ISAC control system design and implementation. As each system was installed a working control system was not too far behind. Several new VME and CAN-bus modules were designed and produced during the year. Some of the group found time to support the CERN projects on the VME timing modules and to initiate a new design project on a VME data acquisition card for the LHC orbit system diagnostics.

MAGNETS

1999 was a busy year for magnet design, construction, and measurement. 16 different types of magnets were worked on during the year.

ISAC

Quadrupoles

The conceptual design of the DRAGON quadrupoles was completed, a design note written and drawings of the magnets completed. The contract for steel manufacture was awarded to Sunrise Engineering (BC) for both 4 in. and 6 in. quadrupoles and they will assemble the magnets. Everson Electric (USA) has the coil contract and they have already delivered the coils. Delivery of the completed magnets is expected in the spring of 2000.

The DTL requires a compact quadrupole triplet to fit between the tanks (Fig. 162). The designs are documented in "Concept design of the ISAC DTL triplet Q2 quadrupole" [TRI-DN-99-09], and "Concept design of the ISAC DTL triplet Q1/3 quadrupole" [TRI-DN-99-10]. By year-end SICOM Industries (BC) had delivered steel assemblies for four triplets, and Danfysik A/S (Denmark) had delivered coils for one triplet. The remaining coils are expected in March, 2000.

The assembly of two Smit-Elma quadrupoles was carried out by the TRIUMF Beam Lines group. The magnets were made from steel assemblies obtained from CERN (solid pole magnets replaced by TRIUMF-

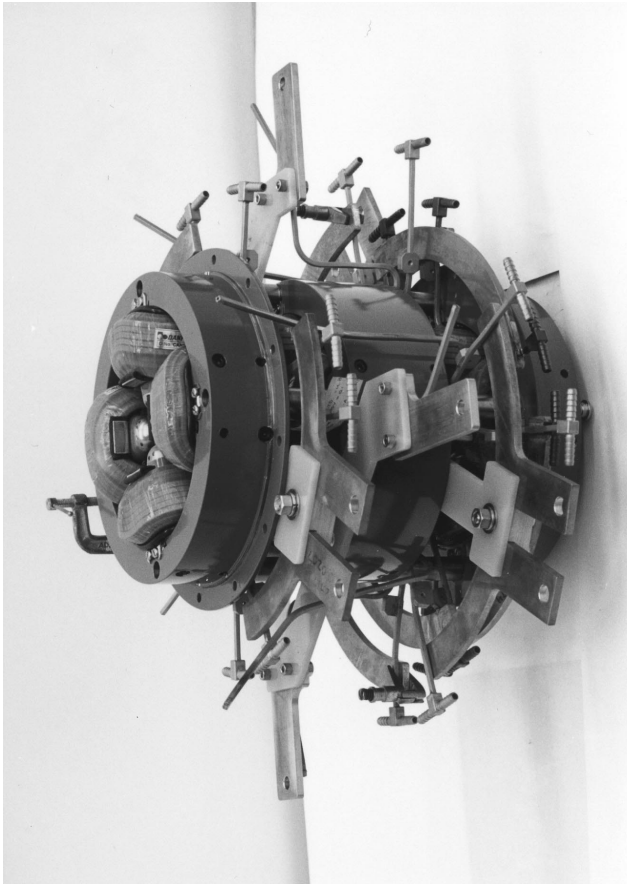

Fig. 162. Photograph of the DTL triplet magnet assembly which has an overall length of 35 cm.

built laminated magnets), and coils supplied by Stangenes Industries (USA). These magnets will be used in the DRAGON separator.

Work on the twin aperture quadrupoles for CERN is described in the CERN section of this report.

Dipoles/steering magnets

The two dipoles MD1 and MD2 for DRAGON were designed last year and sent out to tender. This year, manufacture of the two DRAGON dipoles was completed at Sunrise Engineering, using coils supplied by Stangenes Industries. The manufacture of two MEBT 45° dipoles was carried out at Talvan Machine Shop (BC) using coils supplied by Stangenes Industries. Talvan delivered these magnets in April.

Dehnel Consulting Limited was given a contract to design the ISAC/HEBT 22.5° dipoles. The design note is “22.5° ISAC/HEBT dipole magnet design” [TRI-DN-99-30]. At year-end TRIUMF was out to tender for four dipoles with delivery expected in April, 2000.

The conceptual design of the ISAC and DRAGON steering magnets was documented in design notes “A final design for a 6 in. x-y steerer for the DRAGON facility” [TRI-DNA-99-1], and “A simple 4 in. x-y steerer

for the MEBT beam line” [TRI-DNA-99-2] and drawings completed. SICOM Industries manufactured the steel assemblies for these magnets, and Armature Electric (BC) did the coil fabrication. The 4 in. magnets were assembled at TRIUMF.

Experiment 614 Solenoid

A series of 2D simulations of the Expt. 614 solenoid was carried out to assess the effect of various options of the steel shield upon field uniformity. Members of the Expt. 614 collaboration then developed a 3D model of the solenoid. Discussion of the steel shield design is covered in Mechanical Engineering.

Kickers

The Kicker group designed a mass separator kicker for ISAC that generates variable pulse widths. The design is based on a kicker installed in ISIS and a prototype 10 kV 1 MHz kicker. The mass separator kicker system includes a pair of deflector plates. One plate is driven by a +10 kV FET based modulator. A -10 kV modulator drives the other plate. Each modulator has two stacks of FETs operating in push pull mode with a variable output voltage and a variable repetition rate from 0.1 Hz to 2 Hz. The specifications for the mass separator kicker demand that a stack of FETs must be held in the on state for between 20 ms and 10 s. This relatively long duration required special consideration of component leakage currents and a novel drive technique. The design of the kicker system was completed with the aid of PSpice predictions. Most of the components have been ordered.

Magnet Measurements

A total of 34 magnets was measured this year and these are listed in Table XXVIII.

Table XXVIII. Details of surveyed magnets.

Quantity	Project	Description
3	ISAC	4Q8.5/8.5 quads
2	ISAC	Smit-Elma DRAGON quads
13	ISAC	MEBT quads (Danfysik)
2	ISAC	MEBT 45° dipoles
2	ISAC	Symmetric sextupoles
2	ISAC	Asymmetric sextupoles
1	ISAC	DRAGON MD1 dipole
1	ISAC	DRAGON MD2 dipole
1	ISAC	MEBT double steerer
2	ISAC	MEBT single steerers
5	Canadian Light Source (CLS)	Quadrupoles

B-H curves on various samples of iron silicide were measured for a local firm. For this the calibration magnet was modified to produce 3.6 T over a small volume.

The magnet measurement technician was the only Canadian representative at the International Magnet Measurement Workshop (IMMW11) held at Brookhaven National Laboratory (BNL). A talk entitled “Magnet measurements for the ISAC project at TRIUMF” was presented. This included an overview of the ISAC project and focused on the many magnets required. The two magnet engineers attended the 16th International Conference on Magnet Technology organized in Florida by the National High Magnetic Field Laboratory (NHMFL).

MECHANICAL ENGINEERING

ISAC

Engineering support of the ISAC project continued throughout 1999 as one of the major tasks, although somewhat reduced from that of 1998. The engineering effort ranged from project management to specific design projects involving moving a project from conceptual design through design review, manufacturing and assembly. Work during the year involved the engineering required to complete the target hall, shielding, hall contents and the hot cell, and the engineering support required to move forward on the completion of the contents of the experimental hall, i.e., accelerators, beam lines and DRAGON. This work is briefly described below.

Target hall

Construction of the target hall had been completed prior to 1999, but some elements within the hall remained incomplete. Shielding around the high active water package was designed, built and installed, and the shielding above the pre-separator magnet was completed. There will be a requirement to increase the shielding in the area of the 5B diagnostic station in the future (5B lies between the vacuum tanks and the pre-separator magnet) based on measurements taken to date.

The storage pit was used as a warm cell during 1999 since the hot cell was incomplete and not useable until later in the year. Three storage silos were designed, built and installed later in the year.

The hot cell was completed and commissioned. This involved installation of the manipulators and interior services (see section ISAC Project - Remote Handling, for details). A considerable effort was expended in engineering and building the roof of the hot cell due to inclusion of a vertically adjustable automatic turntable (see Fig. 163). Some engineering time was spent investigating the main bearing rotation problems on the turntable.

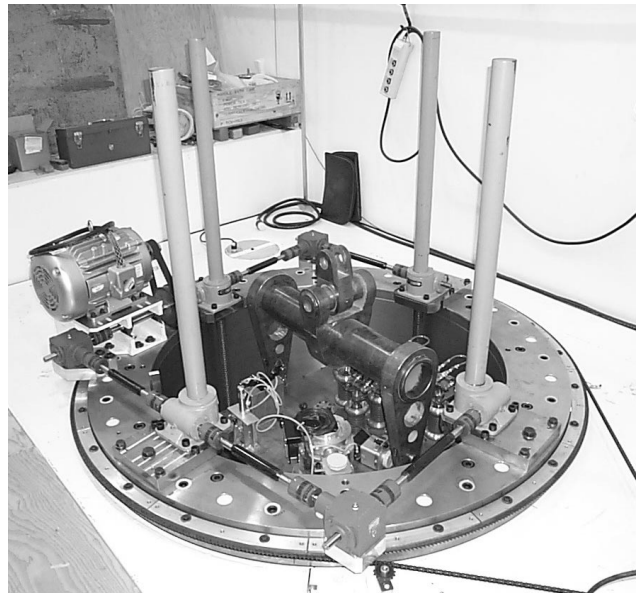

Fig. 163. Photograph of the top of the hot cell showing the vertically adjustable turntable and top of a target module.

Target module

Two new target modules (designated TM2 and TM3) were scheduled to be built this year. It was recognised that certain features of the prototype target module TM1 needed improvement. In addition the new module was required to house an ECR ion source which requires more services as well as a wave guide. This resulted in the redesign of the ducting, shielding and containment box. The new design also improved on the accessibility to the service duct as well as to the containment box contents. TM2 was completed in November, and a special target installed for a scheduled 100 μ A run which was accomplished in December. TM3 was left in a state of 50% completion and will be completed in 2000.

Accelerators

Mechanical engineering support for the RF group continued in the design and construction of ISAC linear accelerators and other rf devices.

The remaining twelve rings were installed and aligned in the RFQ tank along with their associated electrodes, shrouds, and water services. Once complete, rf tests commenced and stable beam was accelerated in August. Transmission and beam quality were as predicted indicating a stable and accurate rf structure (for details see section ISAC Project – RF Systems).

The next rf project scheduled was the 35 MHz MEBT buncher. This device utilized a vacuum tank similar to the already completed DTL tank #1 and enclosed a unique spiral structure terminating in a drift tube. The spiral is water-cooled by milling slots in all

four corners and soldering tubes in these slots. The spiral was later copper plated to avoid problems with the solder sputtering.

Parallel with this work the design and detailing of DTL tanks # 2, 3, 4 and 5 proceeded to completion and the fabrication work was issued for tender in December. Work on the ridges and stems proceeded as well and their packages will be issued for tender in the new year. The DTL support frame and individual tank support cradles were designed and released to the Machine Shop.

DRAGON

A design review was held for the electrostatic dipoles ED1 and ED2 and it was decided to fabricate the titanium electrodes for ED1 and ED2 as welded, instead of bolted, sub-assemblies due to considerable cost savings. These welded sub-assemblies were then stress relieved in a vacuum furnace to minimize surface movement during final machining.

Preliminary bids were obtained for final machining of the electrodes using conventional CNC machining and wire EDM. Since these are difficult parts to machine, with very tight tolerances over rather large surfaces, it was decided to choose the wire EDM method of machining these electrodes. Wire EDM gives much better accuracy and surface finish than conventional

CNC machining. Specifications were written for wire EDM and bid packages sent out for firm bids. It is expected to award the contract for final machining of the electrodes early next year.

Design of the support and alignment system for the electrodes was completed, material has arrived, and the Machine Shop has started machining the parts. Design of the vacuum tanks for ED1 and ED2 has begun. Figure 164 shows a rendered drawing of ED2.

The design of the 300 kV Cockcroft-Walton high voltage multiplier stacks has been completed and a design review held. One stack has been assembled and successfully tested to 156 kV in air (with load), and to 200 kV in a pressure vessel containing 30 psig of SF₆ (without load). Further tests are planned for next year.

ISAC – University of Victoria

The high-current connections to the ISAC target module were redesigned using flexible cables and a non-standard crimp connection. The new crimping tool and procedures have produced connections which are more readily made and are also more reliable and compact. The ISAC exit-1 service ladder was redesigned to fit the duct envelope and ease handling problems.

Engineering – Other

TNF

The TNF aluminum water vessel was replaced with a redesigned vessel of stainless steel. It was necessary to replace the welded joint between the aluminum beam window and the old aluminum vessel with a custom designed knife-edge seal. This seal is machined on the new aluminum window and seals against a mating surface on the new stainless vessel.

Targets

A feasibility study for a sodium iodide target for ¹²²Xe production was started in August. The aim was to search for a thermally efficient design for a molybdenum target vessel that would control the temperature inside the molten sodium iodide target to within a prescribed tolerance while being cooled at one end by water and heated from the other end by a 100 MeV proton beam in the current range 25–50 μA. Water flow is used to compensate for the changes in the beam current. Two design possibilities with a good chance of meeting the design criteria were achieved. Thermal analysis was done using the FEA software from ALGOR. Two reduced scale models based on these two options will be fabricated and tested by February, 2000, to verify the temperature calculations.

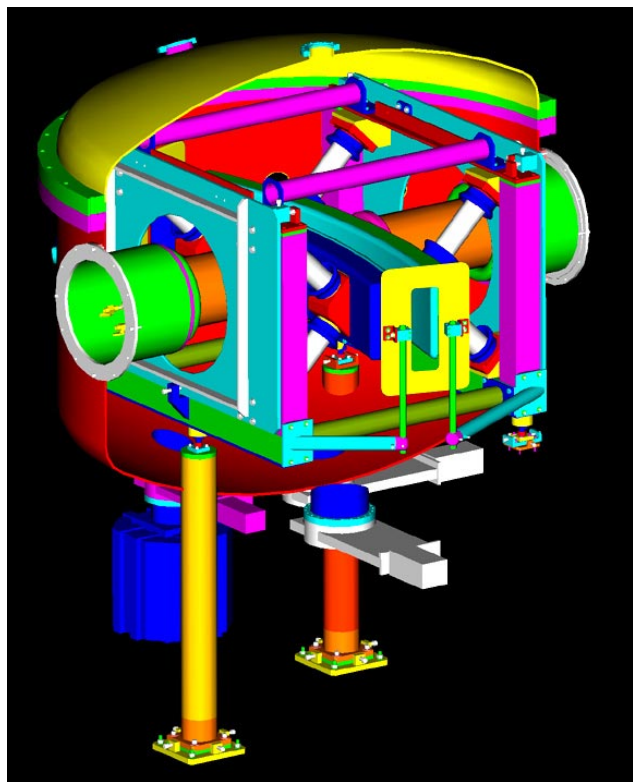

Fig. 164. A rendered view of the DRAGON electrostatic dipole with its vacuum tank.

G0 experiment

The superconducting solenoid mapper design project for the G0 experiment at Jefferson Laboratory was started in August. It is a robotic computer controlled 3-axis gantry frame structure with an operating envelope of 4 m × 4 m × 2 m. It will measure the magnetic fields with a 3-axis Hall effects transducer at the end of a long aluminum boom with a positioning accuracy of 0.25 mm. Engineering design, analysis and a design report have been completed and most components have been ordered with funding being controlled and channeled through the University of Illinois. Engineering assistance will be provided for assembly, software development, calibration, controls system integration, and installation around June, 2000.

Experiment 614

The design of the steel return yoke structure for the Expt. 614 superconducting solenoid was completed to a stage where the steel could be ordered. The 67 tons of low carbon steel plate for this large structure was then ordered in December.

M9 solenoid

Engineering support was provided for the operation and maintenance of the M9B superconducting solenoid and helium refrigerator. This facility has given reasonable service for over ten years.

CERN

The engineering support for the CERN-LHC tasks is described in the CERN section. The design and fabrication of the fast wire scanners was the main activity using engineering and design resources.

ATLAS – University of Victoria

Hadronic endcap (HEC)

Field trips to CERN were made to provide technical assistance in the assembly and removal of HEC modules, built at three collaborating sites, before and after tests in the CERN test beam.

The conceptual design for a cold test support frame has been produced for the HEC production module test program at CERN. A presentation on the tooling and method of assembly of the HEC wheel structure was given at the LARG week in Marseille.

The conceptual design of the container to transport HEC modules to CERN has been completed. Each of the ten payloads of 20 tonnes will be carried in a commercial shipping container with removable top: this will enable crane loading and unloading and rapid container “turnaround” after delivery at CERN. The payload will be mounted on a frame fitted with a spring damper system which allows the container to sustain

a free vertical drop of 300 mm or a transverse collision at a speed of 1 m/s, without exceeding the maximum allowed acceleration of the payload of 3 g vertical and 0.6 g horizontal. Calculations on the required damper and spring parameters have been verified by finite element analysis using the ANSYS code. The detailed mechanical design and drafting has begun at TRIUMF.

Signal feedthrough project

The decision on which of the two types of signal pin carrier technologies was to be used, in the ATLAS signal feedthroughs, was made after completion of tests at ambient and liquid nitrogen temperatures at the University of Victoria and BNL. The decision was made to report at the Feedthrough Production Readiness Review held at CERN early in the year.

A burst test on a pin carrier was required by CERN to confirm their suitability as pressure vessel components. A test piece was manufactured at the University of Victoria and sent to CERN for testing. The required 10 times maximum operating pressure was easily exceeded. A pressure test was made on a bellows section, and the pressure required by the CERN Safety group before “squirring” occurred was confirmed.

A complete feedthrough (without pin carriers but with dummy cold cables) was built and sent to Orsay to allow testing of insertion procedures for the feedthrough in the endcap cryostat.

Agreement on the QC procedures to be adopted in the assembly, welding and testing of the signal feedthroughs was reached with the CERN Safety group, and will be documented in a CERN safety study report.

The warm and cold signal pin carriers are separated by stainless steel bellows, and the enclosed volume is evacuated to provide thermal insulation. Concern was expressed in the Readiness Review on the effect of a leak occurring in the bellows vacuum space. Heat transfer through the bellows vacuum space was studied by calculation and experiments. A scheme of reducing the heat leak due to convection by using sheets of polymethacrylimide foam was developed.

The detailed drawings for all feedthrough production components have been completed. The technical specifications have been written and contracts placed for machining all of the feedthrough mechanical components.

PLANNING

This year the Planning group was involved in planning, scheduling, coordinating and expediting several sub-projects for ISAC; planning and coordinating for two scheduled shutdowns (January 4–April 7, and August 22–November 4); and planning some of the CERN

collaboration projects (fast blade scanner, resonant charging power supplies and pulse forming networks).

ISAC

Various plans and PERTs were prepared and updated regularly with manpower estimates and analysis to identify critical areas and resolve any problems. ISAC priorities were evaluated and the highest priority was assigned to the construction of two new target modules; install and test the 100 μA target by December; complete hot cell, remote controls of target hall crane and air zoning systems by October; and the β -NMR (stage I) tests with RIB by December 6. On the accelerator side the goals included: test the RFQ at 150 keV/u (August); MEBT tests (Test #1 in August and Test #2 in February, 2000); and design of the DTL and HEBT components. Activities were coordinated and expedited, and the above goals were achieved on schedule.

The progress on PERTed activities is described elsewhere in this report under the respective principal group. However, following is a summary of projects along with the major milestones achieved.

Target areas and hot cells

Main work included design, construction and assembly of two new target modules with improved design, manufacturing and servicing procedures, easier handling, and added provisions for the ECR source. One new target module was assembled and installed with the 100 μA test target which was tested successfully at 100 μA on December 17. In preparation for this, 2A was tested at 100 μA with no target on December 10.

RFQ

After installing and testing 7 rings in 1998, the remaining 12 rings were assembled and installed on schedule in July, along with associated rf, services and diagnostic components. The RFQ was tested successfully with first beam on August 16, at 150 keV/u.

MEBT

The MEBT Test #1 with beam was carried out from August–October. It transported beam through the RFQ and transport system of the MEBT up to DB5 with an aim to do Test #2 through the whole MEBT in February, 2000.

Drift tube linac (DTL)

Progress on the DTL was relatively slow due to lack of resources and higher priority on the RFQ and the MEBT tests. The DTL triplets were designed, ordered and steel and coils for triplet 1 were received in December. Detailed design of tank #2 with stems

and ridges was completed along with detailed layout of specifications for tanks #3–5, by December, with an aim to place an order for fabrication of all tanks and support cradles by January, 2000, and stems and ridges by February, 2000.

HEBT

Major jobs included engineering layout, the HEBT dipoles designed and ordered for delivery in April, 2000, and specifications of rf devices (11 MHz and 35 MHz bunchers, chopper, etc.). It was planned to use Chalk River quads for the HEBT, and the 11 MHz buncher was identified to be on the critical path.

Low energy experiments

This included GPS (lifetime), LTNO, yield station and β -NMR. Extensive efforts were spent in planning, coordinating and expediting activities and critical components from the Machine Shop and outside suppliers for the β -NMR and associated LEBT components. The β -NMR was tested slightly ahead of schedule with ^8Li beam on December 3.

CERN

The Planning group was involved in planning and scheduling the activities for fast blade scanner, fast wire scanners with vacuum boxes and stand, five 66 kV resonant power supplies (RCPS), and nine pulse forming networks (PFNs).

Shutdown Activities

The main purpose of this shutdown (January 4–April 7) was to complete MRO work in the cyclotron tank, MRO work on copper active and non-active pumps, and repair water leaks in M20, M9 and TNF. Major jobs completed in this shutdown included: inflector cleaning, wider scraper on UQ2 correction plate assembly, replace inner tank seal, probes MRO (2C, 2A, slit 4), new rf booster feedthrough, centre region polishing, installation of tank neutral monitor to reduce activity near BL2 exit horn.

The main purpose of the fall shutdown (August 22–November 4) was to replace the TNF vessel with a newly fabricated stainless steel vessel, repair water leaks for 1AQ11, M9B1 and M20Q1, necessary MRO in the cyclotron tank, and complete work on ISAC to prepare for the 100 μA test on BL2A. The major jobs completed in this shutdown included: water cooled probes repair, EX4 gate valve activating cylinder and centre region inspections, pump replacement for the Al-ALCW system, repair water leaks at 1AQ11 and M9B1, replacement of the TNF vessel, collimator repair, 1AW2 window seal to fix TNF vacuum leak, and rebuilding of the 500 MeV facility.

DESIGN OFFICE

The ISAC project received the majority of time available at 80% or approximately 12,000 hours, and the Design Office was kept busy preparing conceptual and detailed designs for many different aspects of the project. Specifically, and in order of magnitude, they are: (a) DRAGON electrostatic dipoles, quads and steerers, diagnostic elements and the structural platform for supporting the control modules; (b) target elements for RIB including the target station modules themselves and target conditioning box; (c) MEBT beam line components including the 35 MHz rebuncher; (d) DTL tanks, stems, ridges, coupling loops, tuners, support stands, quad triplet, and the Prague magnet modifications (see Fig. 165); (e) ISAC hot cell and target hall remote handling devices; (f) low energy experimental apparatus for yield, lifetime, LTNO and β -NMR projects; (g) HEBT layouts and sub-

contracting of dipole design; and (h) updating records for maintenance, repair and operational changes.

The CERN contribution accounted for 15.5% of available hours, with most effort concerned with the 66 kV resonant power supply and the fast blade scanner. Because of the concentration of effort required for ISAC, the only other significant TRIUMF projects undertaken were the Expt. 614 superconducting solenoid and the CHAOS LH₂ target. Sub-contract design help, along with continued assistance from the University of Victoria and TRIUMF remote handling, has helped us cope with the heavy workload.

The Design Office moved to the top floor of the ISAC office building during September, with little disruption to service. The demand for graphic art services continues to increase in support of seminars, conferences and publications, and some of this work can be seen on display in the administration building foyer.

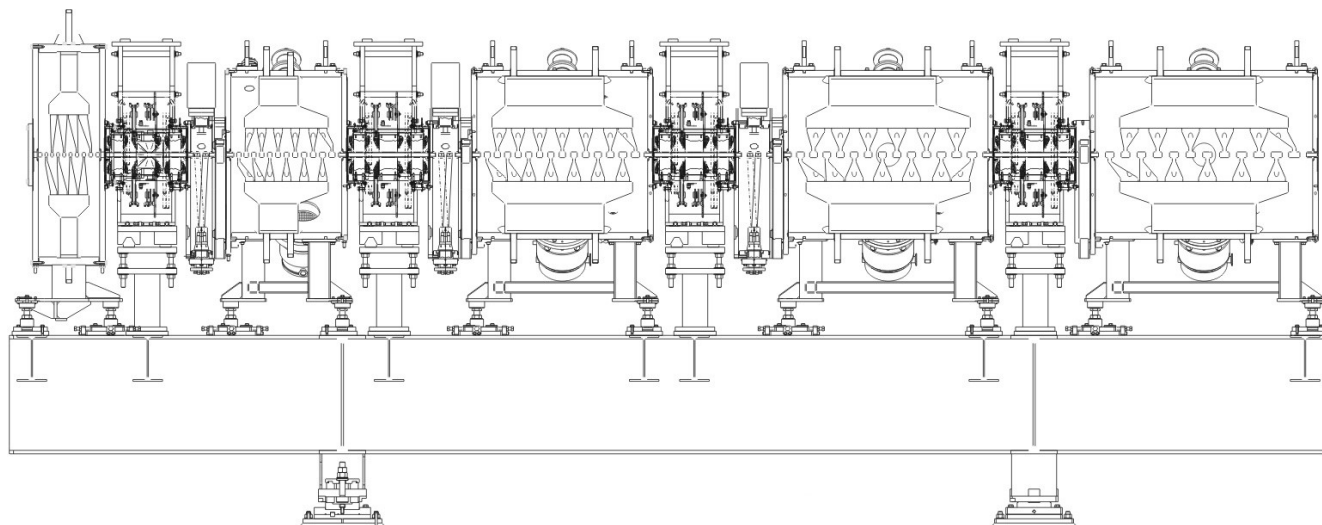

Fig. 165. The assembly of the 5 tanks of the drift tube linac, the quadrupole triplets, and rf bunchers.

MACHINE SHOP

The TRIUMF Machine Shop, with a complement of 21 technicians, produced, fabricated and machined components valued at over \$127,000 per month for various on-site groups. Table XXIX shows the percentage breakdown of this work to the groups.

Table XXIX. Machine Shop utilization.

ISAC	66.6%
CERN	20.8%
Cyclotron	3.8%
Science	3.5%
NSERC	2.1%
Affiliated Institutions	1.6%
Nordion	1.5%

Our facility continues to be fully loaded in all departments. In addition, a total of more than \$500,000 worth of work was sub-contracted in 180 separate contracts through the TRIUMF Machine Shop to local industry.

ISAC was by far the major user of our services again, followed by CERN. The wire scanners for CERN were particularly interesting.

BUILDING PROGRAM

In October, TRIUMF submitted an application for funding of building requirements to the provincial government. For this application the Building department generated a development master plan, together with budget cost estimates and proposal sketches for the ISAC-II experimental hall (service annex and helium

plant), as well as a new engineering building, office building, a building to house Stores and Receiving, a waste handling facility for the Safety group, and an extension to the radio chemistry annex.

Design drawings were completed in the spring, and a construction contract tendered for the interior finish of the second floor in the ISAC service annex. This 3,400 sq.ft. area is now complete and houses the Design Office.

Other finishing projects in the new ISAC facility included the design and tendering of the target source assembly room and the cold laboratory, both in the ISAC service annex one floor below grade; design and casting of six reinforced concrete shielding blocks for the target hall; reinforced concrete hot cell divider wall and installation of hot cell windows; and design and fabrication of three 10 ft. high concrete shielded target storage modules.

The Building department was called upon to design and tender a variety of smaller projects throughout the year, some of which are listed hereto: restoration of the earth shield retaining wall north of the accelerator building; landscaping of various areas after completion of the ISAC facility; paving of the TRIUMF parking lot with recycled asphalt; modifications to the former jack maintenance building to accommodate the carpenter shop; and coordination of design and construction for an extension to the ATLAS clean room in the meson hall extension.

In parallel with the aforementioned projects, maintenance and repair work was carried out on various facilities throughout the year.

ELECTRONICS SERVICES

Overview

Electronics Services were in high demand again this year due to a number of factors. Major efforts were dedicated to ISAC as well as CERN. The aging equipment on site demands constant service and repair and there is a continuing need for upgrading of network facilities and personal computers. A large number of the important control sub-systems on site are maintained by individuals who are being stretched to accomplish this and work on new projects.

Technical Support

Technical Support completed the control system for the CERN fast blade scanner that had been started in 1998. A large effort was given to Expt. 614 that involved laying out three sets of prototype postamp/discriminator boards followed by a 16-channel CAMAC format board. A control board was also designed to allow the remote adjustment and measurement of thresholds plus monitoring of the power

supplies and temperature. Board layouts and modules were designed for ISAC motor systems as well as 500 mA current supplies for μ SR. Firmware maintenance was carried out for the BL2C solid target facility, main tank vacuum system, and the ISAC west target protect TRIMAC systems. Assistance was given to the Electronics Shop during the heavy demands of ISAC cabling installations. Recently, software was developed for a RAM test system for the proton irradiation facility.

Experimental and Target Support

A major effort this year was applied towards working on the CERN 60 kV resonant power supplies. This is a major assembly job involving five large units. This work included specifications and documentation, wiring, PCB assembly, inter-module cabling, interlocks, switch installation and cabling. Maintenance work was carried out for a number of TRIUMF systems including proton therapy and 1AT1 and 1AT2. Assistance was given to site communications, as required, to install cabling in ISAC.

Electronics Shop

This year's major workload for the Electronics Shop was cable requests. The largest component was the ISAC project for which the shop delivered vacuum, temperature, test, SHV and control cables. In addition, we assembled interface and isolation amp boards. CERN took second place with 66 kV kicker cables, modules and panels. For the Cyclotron group, cables and modules including octal breakout panels, V/F converters, PC boards and power supplies were assembled and delivered. The HERMES project required board modifications, diagnostic and isolation modules. There was also a great increase in the production of delay cables for TRIUMF Stores.

Electronics Repair Shop

It was a busy year for the Electronics Repair Shop, with the addition of support for the recently commissioned ISAC facility. In total, 275 electronic devices were repaired or calibrated, including: 7 terminals, 53 monitors (of which 41 were colour models and 12 were monochrome), 26 SCSI and LAN devices, 86 power supplies (including 22 NIM units, 9 CAMAC units, 21 high-voltage units, and 34 miscellaneous types), 34 nucleonics modules (both NIM and CAMAC), 17 varied items of test equipment, and 33 other pieces of miscellaneous electronics. Some of the specialized equipment repairs included Glassman power supplies, turbo pump control boxes, Tektronix oscilloscopes, plus repairing devices for the Machine Shop.

Microprocessor Support

Considerable time and effort was expended on ISAC controls software development (EPICS). Beam optics control systems were implemented and commissioned for the ILTA, ILE, IPL (test stand), ILE1 and ILE2 sub-systems. Building on prior efforts, tools were developed to enhance productivity in building control system software for future ISAC sub-systems, and to improve data flow from design specs to control software deployment. Programming and other computer related consultation to TRIUMF staff was provided, including core development of a Web-based search engine for CCS controls hardware documentation.

High level software support

The BL2A extraction probe control system was modified to deal with some operating problems. The BL2C extraction probe was decommissioned and recommissioned for the fall shutdown. A major error in TRIMAC FORTRAN software was discovered while modifying the proton therapy water box motor controls, and was rectified. The coding error discovered is common to other systems which will require review and modifications, if necessary. A major failure in the M15 separator HV power supplies was repaired. ISAC saw several motor systems installed, including the RFQ diagnostics and yield station. Some tests were run on the Danfysik wire scanner unit for the Diagnostics group. Motor drive units were built for the MEBT slits and jaws. Extensive work was done on the data acquisition system for the LTNO target to ensure the system collected data correctly. Work for CERN included the Tekanal data analysis program and the kicker magnet CapReader program to collect data on the special HV kicker capacitors. The Data Acquisition group required support for the CAMP data acquisition system. This included an upgrade to VxWorks 5.3, construction and testing of a DC motor driver for cryostat valves, a software driver for a flash RAM-based disk drive in the PowerPC computer boards, and a complete CAMP system for the β -NMR experiment in ISAC.

PC support

A number of major tasks were completed throughout the year. These were the relocation of the Design Office server, workstations and printers, and the set-up of a small network for TRIUMF House. Other issues were addressed such as developing the TRIUMF desktop support Web site, preparing a proposal for a backup solution for the Design Office, maintaining the PC hardware standards at TRIUMF, and coordinating meetings for the PC Hardware Committee. The primary function of the position continues to be the maintenance of PCs on site which included 1000+

calls for work such as: hardware repairs, configurations, software installations, new PC checkouts, used PC rebuilds, assistance with network problems and evaluation of new hardware or software. PC support was aggressive in informing all site PC users of potential Y2K problems on their machines. Information was e-mailed to everyone, notices posted and also put in all mail boxes.

It was recognized this year that PC support, with a single individual, was extremely overburdened. A new part-time position titled "PC network and application support" was created starting in the last quarter. The eventual function of this position will develop, but at the moment it includes supporting the Design Office, managing the Novell servers, liaising with Computing Services, and providing backup for the PC support position. The most immediate task will be to provide file backup services to the general PC populace. CFAT approved a proposal for this file backup services system that had been put forward after much research, testing and evaluation. The new system will be installed in stages to gauge its progress, but is expected to be fully operational by the summer of 2000.

Site Communications

The major jobs for Communications revolved again around the ISAC installation. The first major installation was a 12-strand fibre backbone between ISAC and the chemistry annex, to allow reliable high-speed access from the new facility. Other ISAC related jobs were the cabling of the LE area, plus installation of cabling for the entire PA system. A major relocation of the Design Office was accomplished with a well coordinated effort installing a new communications system. A major upgrade to the site cabling was started in earnest, with 100 base-T cabling installed to all three floors in the chemistry annex, meson hall counting rooms, theory wing and a few other isolated areas that required better transfer rates. Other jobs included a hub for the kicker laboratory, plus some networking for TRIUMF House. To help reduce the communications saturation of trailer "Gg", trailer "Rr" was relocated to a separate backbone.

ELECTRONICS DEVELOPMENT

This year again, the majority of the group's effort went to support of the ISAC control system design and installation, together with the CERN collaboration. Between February and September, one BCIT co-op student was supervised.

ISAC Support

The CAN-bus power supply controllers received minor firmware upgrades. A special version for control of

the Chalk River Danfysik quadrupole supplies was developed. This card was installed in 13 supplies which are used for the ISAC MEBT section. Several adapter cards for the general purpose controller, to different supplies, were developed.

A VME-based harp readout module for up to 96 wires was developed as a replacement for the NIM-based 0518. Tests at ISAC showed that the new module reliably measures wire currents down to 1 pA. Five modules were built, tested and installed at ISAC and tests were conducted with the DRAGON blade profile monitor.

The design of an 8-channel VME-based bias supply for beam current monitors, which is programmable from 60 to 300 V output, was finished. Three modules were produced, tested and installed at ISAC.

Design work was finished for a VME crate monitor and reset module for ISAC. The module monitors crate voltages, temperatures and fan operation. It also contains watchdog registers for monitoring software activity in the EPICS CPU. A CAN-bus interface allows interconnecting of several crate monitors. Each module can communicate the state of its own crate to all other modules on the CAN-bus loop. This information is available to the EPICS CPU via the VME backplane.

Additional modules produced for ISAC during the year included:

- VME 32-channel digital I/O modules;
- 35 VME VQSX 8-channel beam current amplifiers;
- 250 CAN-bus power supply controllers.

The fibre optic signal transmitters for the ISAC ^8Li polarizer were completed and tested at the ion source test stand.

For the DRAGON electrostatic dipole 300 kV supplies, simulations of the proposed high voltage stack design began in February. Work continues with testing the prototype stack at full voltage, and determining the effect of SF_6 gas pressure on performance.

For the Data Acquisition group, an 8-channel NIM module was designed and built for 120 MHz NIM level to fibre optic conversion.

For DRAGON and the ISAC HEBT section, work has started on the design of a CAN-bus based, low cost, Hall probe front end and data acquisition board. Design specifications ask for a repeatability of one part in 10,000.

For the Kicker group, assistance was given for capacitor testing and a 1 kV calibration probe was designed and built. Board layout was done for the ISAC low energy chopper.

Design work has started on a gated current digitizer and averaging circuit with VME interface to process ion chamber signals for Expt. 497.

CDS

Work on the CDS power supplies has ended with the writing of a final progress report in June.

Nordion TR30

Services were supplied, as required, to maintain the rf and rf control systems.

CERN

Earlier in the year, eight more timing surveillance VME modules (TSM) were tested and shipped to CERN. A final batch of 30 modules was built and tested in the fall.

Support continued for the fast blade scanner (FBS) project. Following shipment to CERN of the FBS and associated control electronics, a member of the group spent two weeks at CERN. The control and data acquisition software which was used for testing at TRIUMF was adapted to the CERN controls environment. This involved converting the VxWorks drivers to LynxOS and incorporating them in an equipment module.

LHC orbit system

Preliminary discussions were held at CERN during the spring and at TRIUMF later in the year. As a result the group has been charged with the following tasks.

- Design of a 40 MHz acquisition card in VME.
- Writing of an application program in the CERN environment.

Three cards will be used for beam tests at CERN during the year 2000. In total, about 1,000 cards will be required. To aid in card testing and software design, a complete software development package has been received on loan from CERN. This consisted of a PC running Linux and a VME system running LynxOS. This will facilitate the writing of all application codes in the CERN environment. During November, a member of the CERN SPS Controls group spent a week at TRIUMF setting up the system.